



DELTA ELECTRONICS, INC.

Braking Modules

User Manual



VFDB Series Braking Units
VFDB 2015/2022/4030/4045



BR Series Braking Resistors





DELTA ELECTRONICS, INC.

www.deltaww.com/acdrives

ASIA

DELTA ELECTRONICS, INC.

Taoyuan Plant

31-1, SHIEN PAN ROAD,
KUEI SAN INDUSTRIAL ZONE,
TAOYUAN SHIEN, TAIWAN.

TEL: 886-3-362-6301

FAX: 886-3-362-7267

EUROPE

DELTRONICS (NETHERLANDS) B.V.

INDUSTRIEGEBIED VENLO NR. 9031

COLUMBUSWEG 20
NL-5928 LC VENLO
THE NETHERLANDS

TEL: 31-77-324-1930

FAX: 31-77-324-1931

NORTH/SOUTH AMERICA

DELTA PRODUCTS CORPORATION

Sales Office

P.O. BOX 12173
5101 DAVIS DRIVE
RESEARCH TRIANGLE PARK,
NC 27709, U.S.A.

TEL: 1-919-767-3813

FAX: 1-919-767-3969

5011601101
200309-19



UE02

Preface

Congratulations on your purchase of DELTA's braking module. VFDB braking units are applied to absorb the motor regeneration energy when the three phase induction motor stops by deceleration. With VFDB braking unit, the regeneration energy is dissipated by braking resistors. To avoid mechanical or human injury, please refer to this user manual before wiring.

VFDB braking units are suitable for DELTA AC Motor Drives VFD Series 230V/460V. VFDB braking units need to be used in conjunction with BR series braking resistors to provide the optimum braking characteristics.

VFDB braking units (2015, 2022, 4030 and 4045) are approved by Underwriters Laboratories, Inc. (UL) and Canadian Underwriters Laboratories (cUL)

Chapter 1 Specification	1
Chapter 2 Dimension	2
Chapter 3 Individual Parts and Function Explanation	3
Chapter 4 Basic Wiring Diagram.....	4
Chapter 5 Wiring Notice	5
Chapter 6 Definition for Braking Usage ED	6
Chapter 7 Setting and Regulation.....	7
Chapter 8 Summary for Braking Units and Braking Resistors	9
Chapter 9 Wiring Examples of Braking Resistors	10

CHAPTER 1 SPECIFICATION

1. Specification of VFDB Braking Units

VFDB-Specification		Model	230V Series		460V Series	
			2015	2022	4030	4045
Max. Motor Capacity (KW)			15	22	30	45
Output Rating	Max. Peak Discharge Current (A) 10%ED		40	60	40	60
	Continuous Discharge Current (A)		15	20	15	18
	Braking Start-up Voltage (DC)		330/345/360/380/400/415±3V		660/690/720/760/800/830±6V	
Input Rating	DC Voltage		200~400VDC		400~800VDC	
Protection	Heat Sink Overheat	Temperature over +95°C				
	Alarm Output	Relay contact 5A120VAC/28VDC (RA, RB, RC)				
	Power Charge Display	Blackout until bus (+~-) voltage below 50VDC				
Usage Environment	Installation Location	Indoor (no corrosive gases, metallic dust)				
	Operating Temperature	-10°C ~+50°C				
	Storage Temperature	-20°C ~+60°C				
	Humidity	90%R.H., Non-condensing				
	Vibration	9.8m/s ² (1G) under 20Hz 2m/s ² (0.2G) at 20~50Hz				
Mechanical Configuration		Wall-mounted enclosed type IP50				

2. Specification of Braking Resistors

Model no.	Specification	
BR1K5W005	1500W	5.0Ω
BR1K2W6P8	1200W	6.8Ω
BR1K2W008	1200W	8.0Ω
BR1K5W040	1500W	40Ω
BR1K0W050	1000W	50Ω

CHAPTER 2 DIMENSION

Braking unit

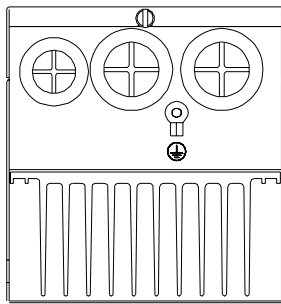
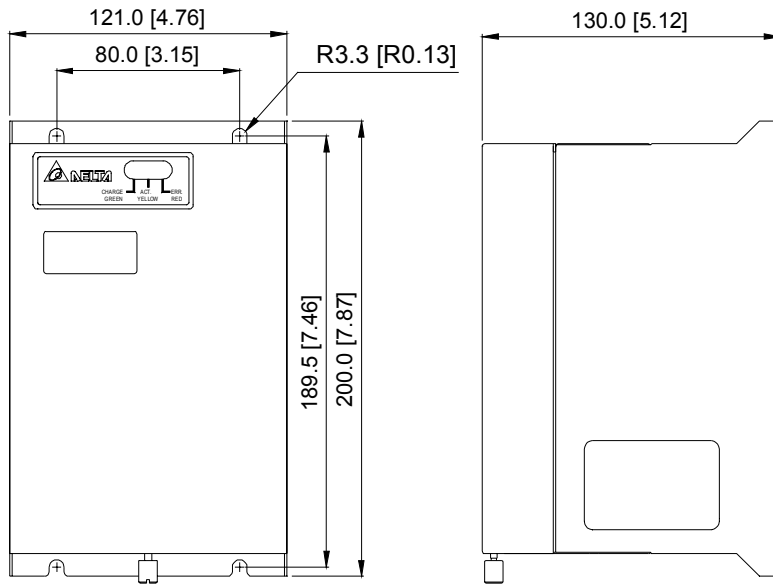

Braking resistor

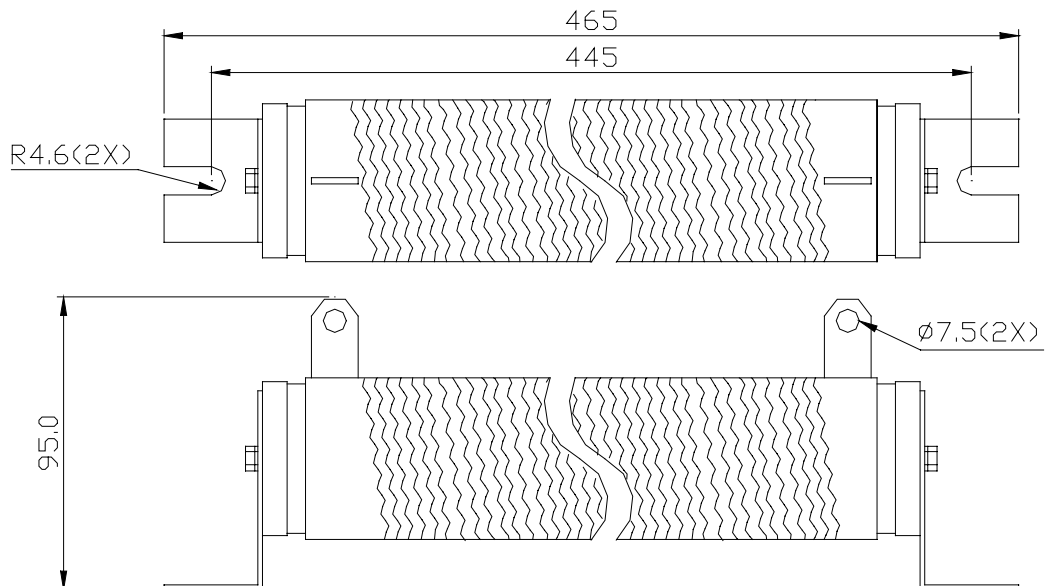

CHAPTER 3 INDIVIDUAL PARTS AND FUNCTION EXPLANATION



- Terminal Wire Gauge

Circuit	Terminal Mark	Wire Gauge AWG/mm ²	Terminal	Torque
Power Input Circuit	+(P), -(N)	10~12AWG/3.5~5.5mm ²	M4 Screw	18 KG-CM
Braking Resistor	B1, B2	10~12AWG/3.5~5.5mm ²	M4 Screw	18 KG-CM
SLAVE and Fault Circuit	M1, M2 S1, S2 RA, RB, RC	20~18AWG/0.25~0.75mm ² M1, M2, S1, S2 with shielded wires	M2 Screw	4 KG-CM

CHAPTER 4 BASIC WIRING DIAGRAM

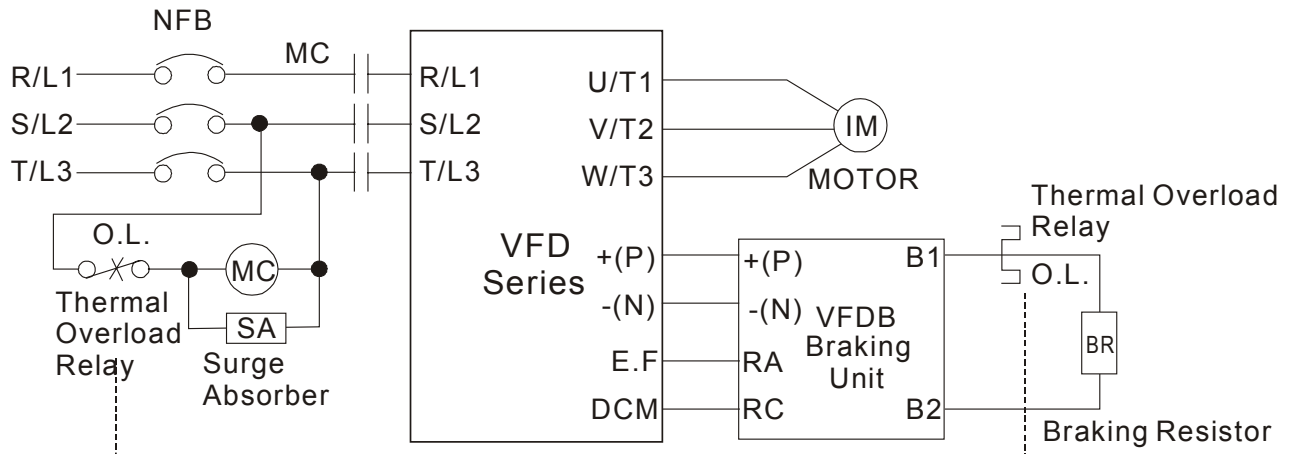

Note 1: When AC drive uses with DC reactor, please refer to wiring diagram in AC drive user manual for the wiring of terminal +(P) of Braking unit.

Note 2: **Do NOT** wire terminal -(N) to neutral point of power system.

● Operation Explanation:

1. For safety consideration, install an overload relay between the braking unit and the braking resistor. In conjunction with the magnetic contactor (MC) prior to the drive, it can perform complete protection against abnormality.
2. The purpose of installing the thermal overload relay is to protect the braking resistor from damage due to frequent braking, or due to braking unit keeping operating resulted from unusual high input voltage. Under such circumstance, just turn off the power to avoid damaging the braking resistor.
3. Please refer to chapter 3 for the specification of the thermal overload relay.
4. The alarm output terminals (RC, RA, BB) of the braking unit will be activated when the temperature of the heat sink exceeds 95°C . It means that the temperature of the installation environment may exceed 50°C , or the braking %ED may exceed 10%ED. With this kind of alarm, please install a fan to force air-cooling or reduce the environment temperature. If the condition not due to the temperature, the control circuit or the temperature sensor may have been damaged. At this time, please send the braking unit back to the manufacturer or agency for repair.
5. The AC Motor Drive and braking unit will be electrified at the same time while turning on the NFB (No-fuse breaker). For the operation/stop method of the motor, please refer to the user manual of the AC Motor Drives VFD Series. The braking unit will detect the inner DC voltage of the AC motor drive when it stops the motor by deceleration. The extra regeneration will be dissipated away rapidly by the braking resistor in the form of heat. It can ensure the stable deceleration characteristic.

CHAPTER 5 WIRING NOTICE

- ⚠ 1. Do not proceed with wiring while power is applied to the circuit.
- ⚠ 2. The wiring gauge and distance must comply with the electrical code.
- ⚠ 3. The +(P), -(N) terminals of the AC motor drive (VFD Series), connected to the braking unit (VFDB), must be confirmed for correct polarity lest the drive and the braking unit be damaged when power on.
- ⚠ 4. When the braking unit performs braking, the wires connected to +(P), -(N), B1 and B2 would generate a powerful electromagnetic field for a moment due to high current passing through. These wires should be wired separately from other low voltage control circuits lest they make interference or mis-operation.

- ⚠ 5. Wiring distance

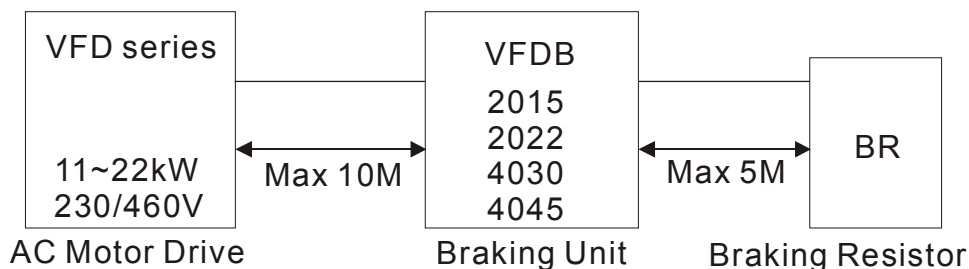

- ⚠ 6. **Inflammable solids, gases or liquids must be avoided at the location where the braking resistor is installed. The braking resistor had better be installed in individual metallic box with forced air-cooling.**
- ⚠ 7. Connect the ground terminal to the Earth Ground. The ground lead must be at least the same gauge wire as leads +(P), -(N).
- ⚠ 8. Please install the braking resistor with forced air-cooling or the equivalent when frequent deceleration braking is performed (over 10%ED).
- ⚠ 9. **To avoid personal injury, do not connect/disconnect wires or regulate the setting of the braking unit while power on. Do not touch the terminals of related wiring and any component on PCB lest users be damaged by extreme dangerous DC high voltage.**
- ⚠ 10. The ring terminals are suggested to be used for main circuit wiring. Make sure the terminals are fastened before power on.

CHAPTER 6 DEFINITION FOR BRAKING USAGE ED%

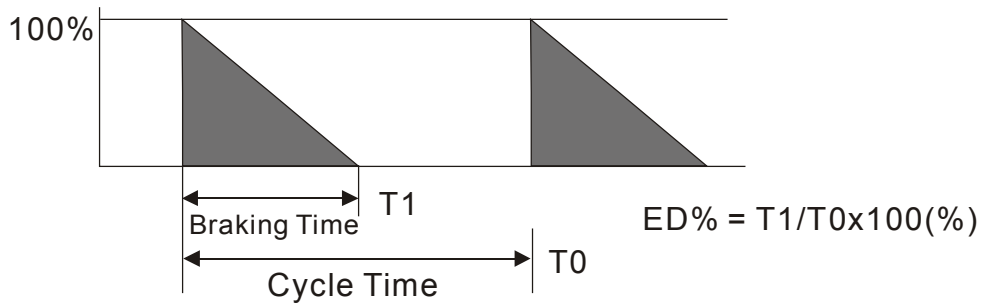

- Explanation:

The definition of the braking usage ED(%) is for assurance of enough time for the braking unit and braking resistor to dissipate away heat generated by braking. When the braking resistor heats up, the resistance would increase with temperature, and braking torque would decrease accordingly.

CHAPTER 7 SETTING AND REGULATION

1. Regulation of power voltage: the power source of the braking unit is DC voltage from +(P), -(N) terminals of the AC motor drive. It is very important to set the power voltage of the braking unit based on the input power of the AC motor drive before operation. The setting has a great influence on the potential of the operation voltage for the braking unit. Please refer to the table below.

Table 1: The Selection of Power Voltage and Operation Potential of PN DC Voltage

230V Model AC Power Voltage	Braking Start-up voltage DC Bus +(P), -(N)) Voltage	460V Model AC Power Voltage	Braking Start-up voltage DC Bus +(P), -(N)) Voltage
190Vac	330Vdc	380Vac	660Vdc
200Vac	345Vdc	400Vac	690Vdc
210Vac	360Vdc	415Vac	720Vdc
220Vac	380Vdc	440Vac	760Vdc
230Vac	400Vdc	460Vac	800Vdc
240Vac	415Vdc	480Vac	830Vdc

Input Power With Tolerance $\pm 10\%$

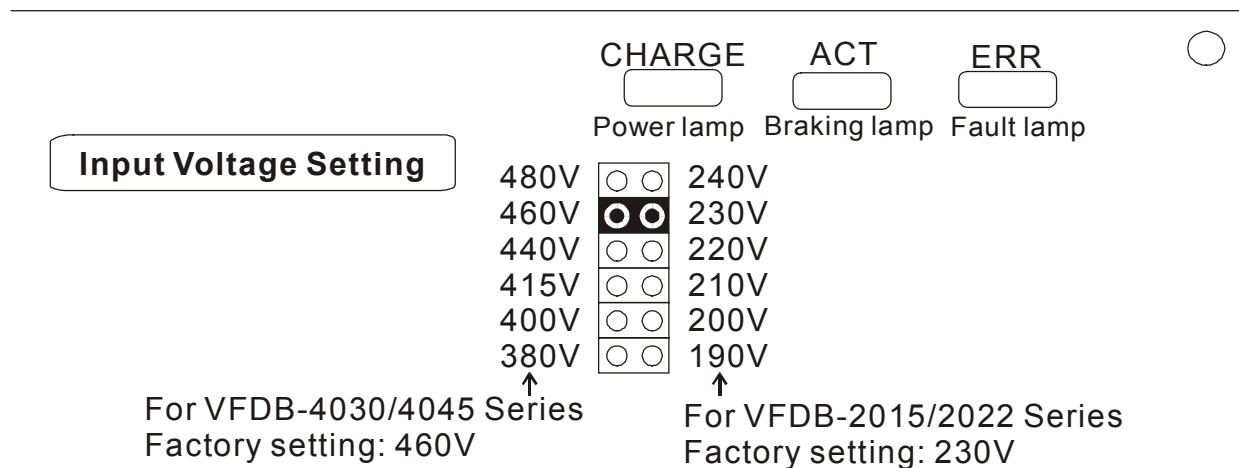

- Note: A. Before regulating the power voltage, make sure the power has been turned off.
- B. Please set power voltage as the possible highest voltage for unstable power system. Take 380VAC power system for example. If the voltage may be up to 410Vac, 415VAC should be regulated.
- C. For DELTA's AC motor drive VFD Series, please set parameter (Over Voltage Stall Prevention) as "close" to disable over-voltage stall prevention, to ensure stable deceleration characteristic.

2. MASTER/SLAVE setting: The MASTER/SLAVE jumper is set “MASTER” as factory setting. The “SLAVE” setting is applied to two or more braking units in parallel, making these braking units be enabled/disabled synchronously. Then the power dissipation of each unit will be equivalent so that they can perform the braking function completely.

● Wiring Example:

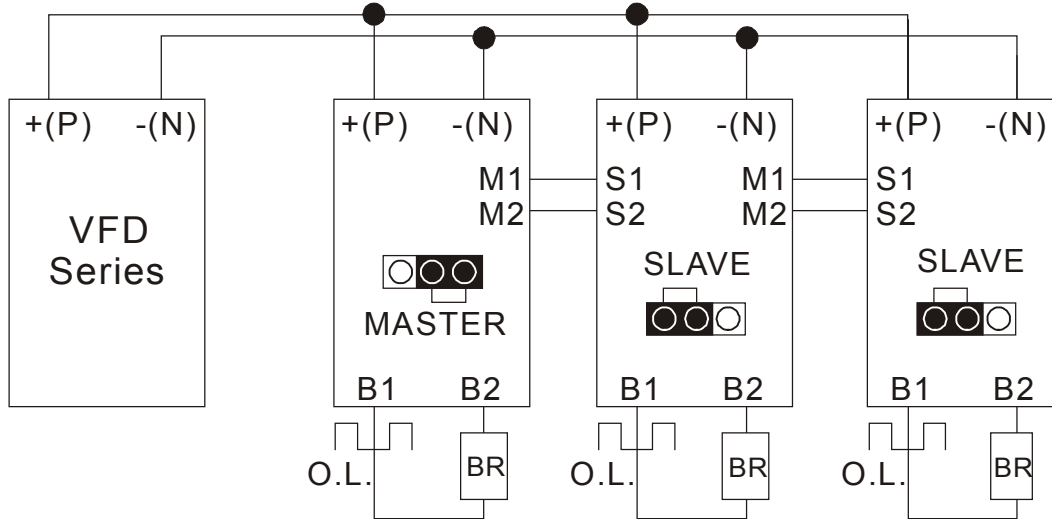

The SLAVE braking application of three braking units is shown as the above diagram. After wiring, the jumper of first unit shall be set as “MASTER” and that of others must be set as “SLAVE” to complete the system installation.

● The position of the jumper:

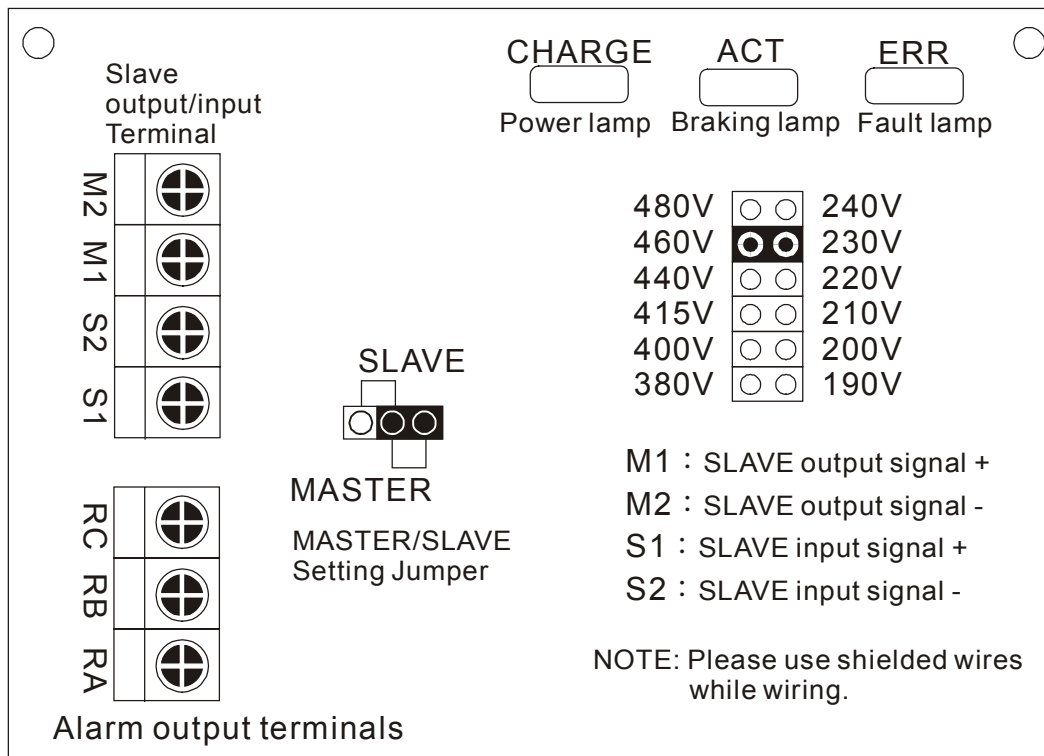

CHAPTER 8 ALL BRAKING RESISTORS & BRAKING UNITS USE IN AC DRIVES

AC Drive		Braking Unit		Discharged Resistor				Braking Torque 10%ED	Typical Thermal Overload Relay Value
Voltage	Applicable Motor KW(HP)	Model Number- VFDB	Numbers	Resistor Specification for a Resistor	Numbers	Model Number- BR	Equivalent Resistors Specification for Each Braking Unit		
230V	11(15)	2015	1	1200W 6.8Ω	2	1K2W6P8	2400W 13.6Ω	125	20A
	15(20)	2015	1	1500W 5Ω	2	1K5W005	3000W 10Ω	125	30A
	18.5(25)	2022	1	1200W 8Ω	4	1K2W008	4800W 8Ω	125	35A
	22(30)	2022	1	1200W 6.8Ω	4	1K2W6P8	4800W 6.8Ω	125	40A
	30(40)	2015	2	1500W 5Ω	4	1K5W005	3000W 10Ω	125	30A
	37(50)	2015	2	1500W 5Ω	4	1K5W005	3000W 10Ω	100	30A
	45(60)	2022	2	1200W 6.8Ω	8	1K2W6P8	4800W 6.8Ω	120	30A
460V	11(15)	4030	1	1000W 50Ω	1	1K0W050	1000W 50Ω	135	10A
	15(20)	4030	1	1500W 40Ω	1	1K5W040	1500W 40Ω	125	15A
	18.5(25)	4030	1	1200W 8Ω	4	1K2W008	4800W 32Ω	125	15A
	22(30)	4030	1	1200W 6.8Ω	4	1K2W6P8	4800W 27.2Ω	125	20A
	30(40)	4030	1	1500W 5Ω	4	1K5W005	6000W 20Ω	125	30A
	37(50)	4045	1	1200W 8Ω	8	1K2W008	9600W 16Ω	125	40A
	45(60)	4045	1	1200W 6.8Ω	8	1K2W6P8	9600W 13.6Ω	125	50A
	55(75)	4030	2	1500W 5Ω	8	1K5W005	6000W 20Ω	125	30A
	75(100)	4045	2	1200W 6.8Ω	16	1K2W6P8	9600W 13.6Ω	125	50A

CHAPTER 9 WIRING EXAMPLES OF BRAKING RESISTORS

NOTE: Before wiring, please notice equivalent resistors value shown in the column “Equivalent resistors specification for each braking unit” in the previous page to avoid damage.

1. For 230V 15HP/20HP:

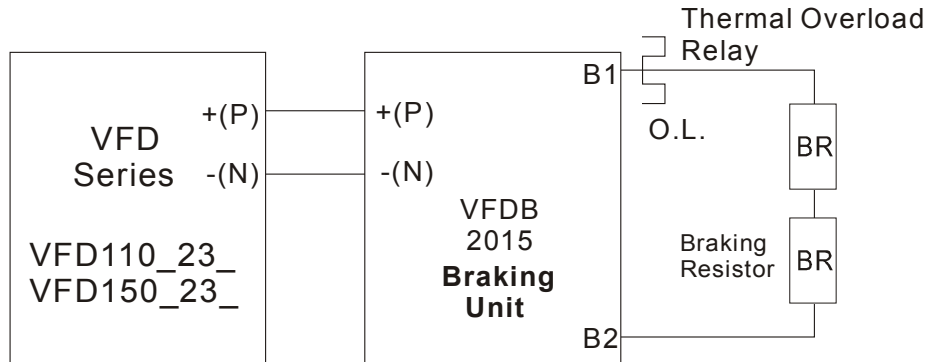

VFD110_23_ uses with 2PCS BR1K2W6P8 braking resistors in series
 VFD150_23_ uses with 2PCS BR1K5W005 braking resistors in series

2. For 230V 25HP/30HP :

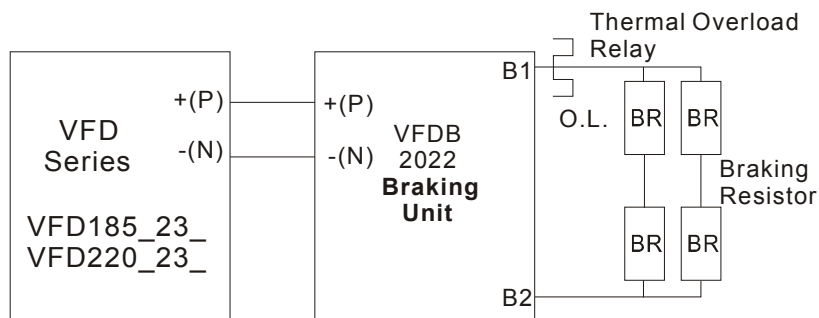

VFD185_23_ uses with two BR sets in parallel, which 2PCS BR1K2W008 braking resistors in series for each BR set.
 VFD220_23_ uses with two BR sets in parallel, which 2PCS BR1K2W6P8 braking resistors in series for each BR set.

3. For 230V 40HP/50HP:

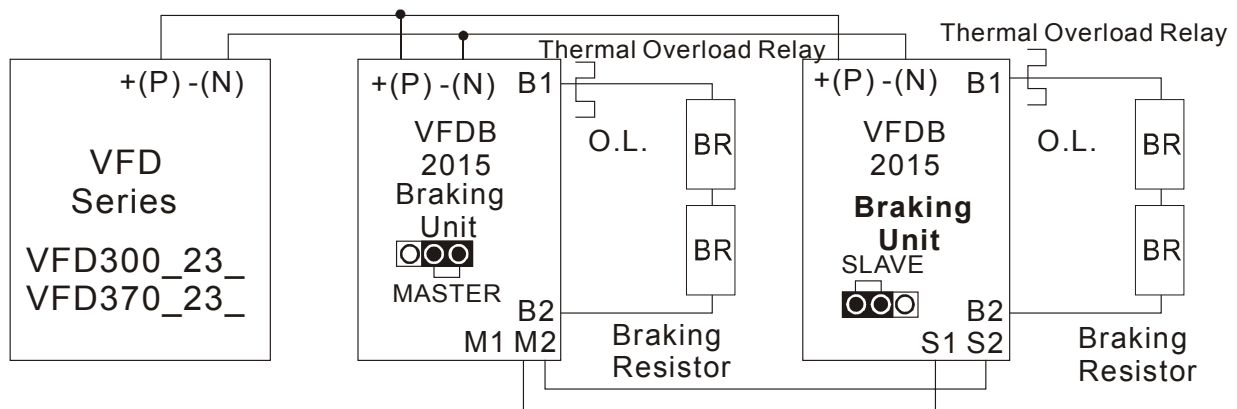

VFD300_23_ / VFD370_23_ use with two VFDB2015 braking units, and each braking unit uses with 2PCS BR1K5W005 braking resistors in series.

4. For 230V 60HP:

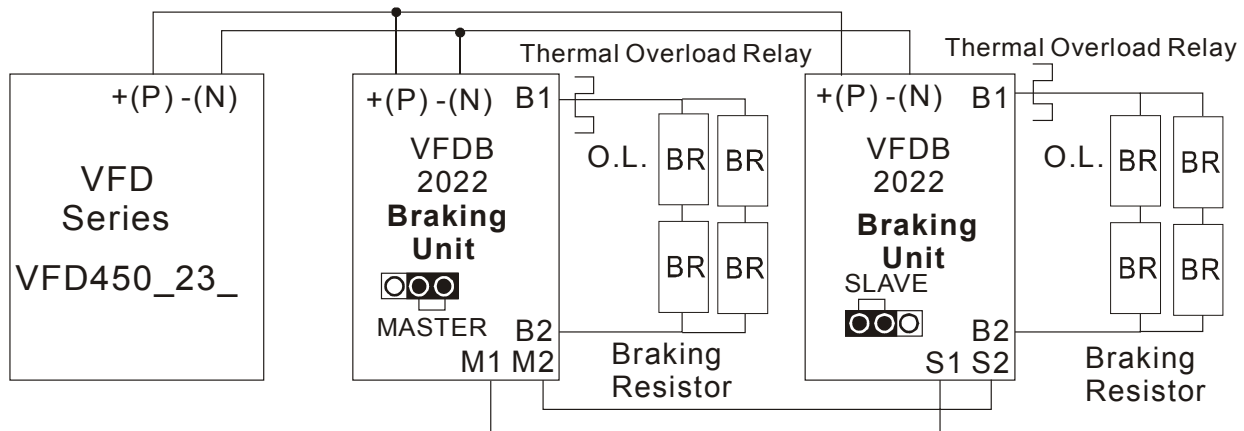

VFD450_23_ uses with two VFDB2022 braking units, and each braking unit uses with two BR sets in parallel, which 2PCS BR1K2W6P8 braking resistors in series.

5. For 460V 15HP/20HP:

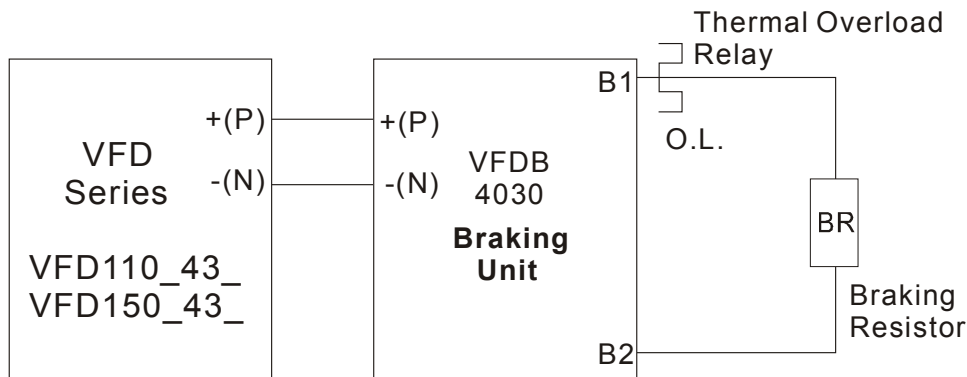

VFD110_43_ uses with 1PCS BR1K0W050 braking resistor
 VFD150_43_ uses with 1PCS BR1K5W040 braking resistor

6. For 460V 25HP/30HP/40HP:

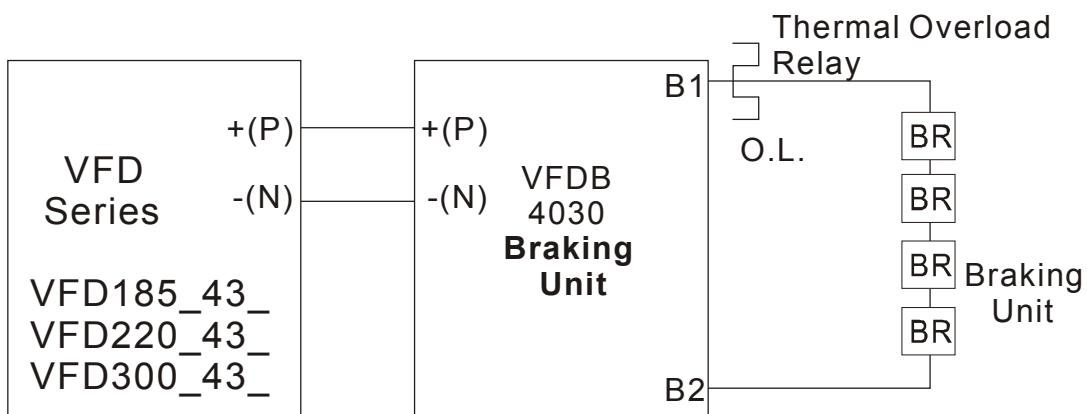

VFD185_43_ uses with 4PCS BR1K2W008 braking resistors in series
 VFD220_43_ uses with 4PCS BR1K2W6P8 braking resistors in series
 VFD300_43_ uses with 4PCS BR1K5W005 braking resistors in series

7. For 460V 50HP/60HP:

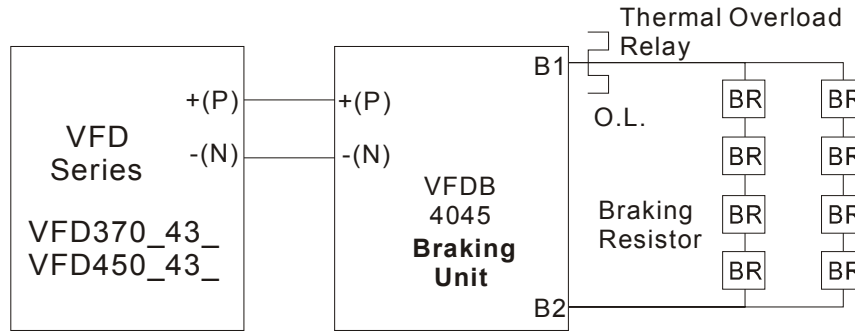

VFD370_43_ uses with two BR sets in parallel, which 4PCS BR1K2W008 braking resistors in series for each BR set.

VFD450_43_ uses with two BR sets in parallel, which 4PCS BR1K2W6P8 braking resistors in series for each BR set.

8. For 460V 75HP:

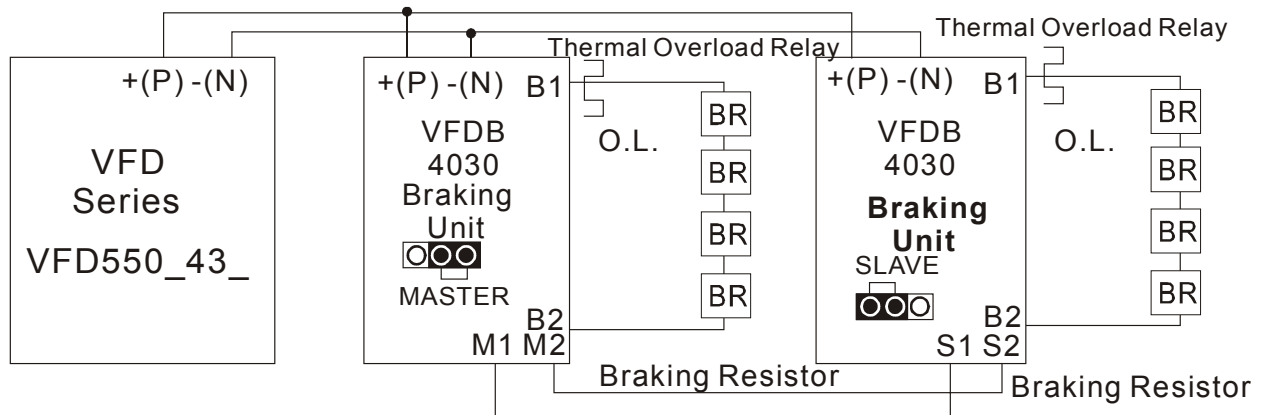

VFD550_43_ uses with two VFDB4030 braking units, and each braking unit uses with 4PCS BR1K5W005 braking resistors in series.

9. For 460V 100HP:

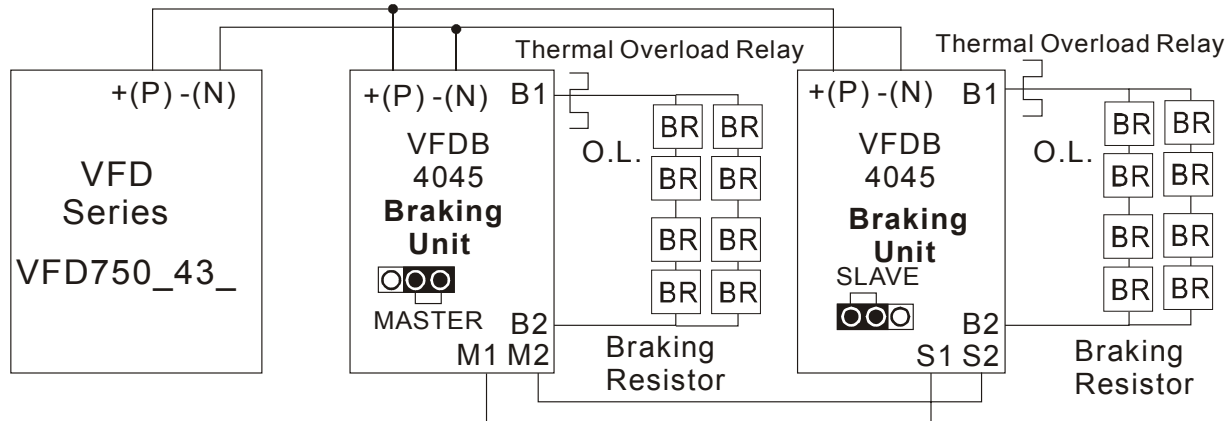

VFD750_43_ uses with two VFDB4045 braking units, and each braking unit uses with two BR sets in parallel, which 4PCS BR1K2W6P8 braking resistors in series.

Document Update

CHAPTER 8 ALL BRAKING RESISTORS & BRAKING UNITS USE IN AC DRIVES

AC Drive		Braking Unit		Discharged Resistor				Braking Torque 10%ED	Typical Thermal Overload Relay Value
Voltage	Applicable Motor KW(HP)	Model Number-VFDB	Numbers	Resistor Specification for a Resistor	Numbers	Model Number-BR	Equivalent Resistors Specification for Each Braking Unit		
230V	11(15)	2015	1	1200W 6.8Ω	2	1K2W6P8	2400W 13.6Ω	125	20A
	15(20)	2015	1	1500W 5Ω	2	1K5W005	3000W 10Ω	125	30A
	18.5(25)	2022	1	1200W 8Ω	4	1K2W008	4800W 8Ω	125	35A
	22(30)	2022	1	1200W 6.8Ω	4	1K2W6P8	4800W 6.8Ω	125	40A
	30(40)	2015	2	1500W 5Ω	4	1K5W005	3000W 10Ω	125	30A
	37(50)	2015	2	1500W 5Ω	4	1K5W005	3000W 10Ω	100	30A
	45(60)	2022	2	1200W 6.8Ω	8	1K2W6P8	4800W 6.8Ω	120	30A
460V	11(15)	4030	1	1000W 50Ω	1	1K0W050	1000W 50Ω	135	10A
	15(20)	4030	1	1500W 40Ω	1	1K5W040	1500W 40Ω	125	15A
	18.5(25)	4030	1	1200W 8Ω	4	1K2W008	4800W 32Ω	125	15A
	22(30)	4030	1	1200W 6.8Ω	4	1K2W6P8	4800W 27.2Ω	125	20A
	30(40)	4030	1	1500W 5Ω	4	1K5W005	6000W 20Ω	125	30A
	37(50)	4045	1	1200W 8Ω	8	1K2W008	9600W 16Ω	125	40A
	45(60)	4045	1	1200W 6.8Ω	8	1K2W6P8	9600W 13.6Ω	125	50A
	55(75)	4030	2	1500W 5Ω	8	1K5W005	6000W 20Ω	125	30A
	75(100)	4045	2	1200W 6.8Ω	16	1K2W6P8	9600W 13.6Ω	125	50A

CHAPTER 9 WIRING EXAMPLES OF BRAKING RESISTORS

NOTE: Before wiring, please notice equivalent resistors value shown in the column “Equivalent resistors specification for each braking unit” in the previous page to avoid damage.

1. For 230V 15HP/20HP:

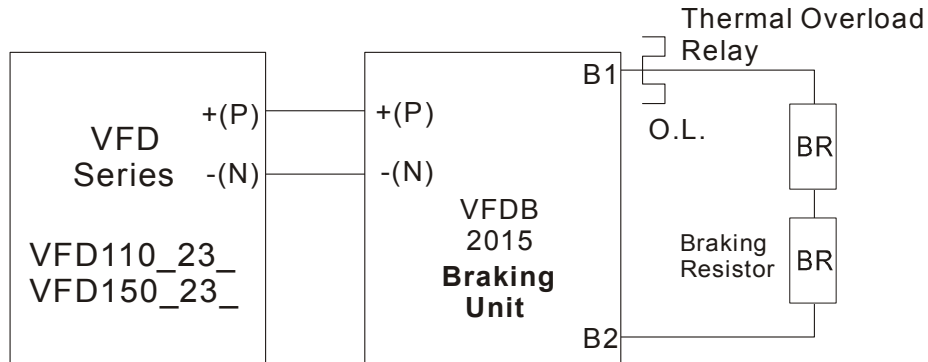

VFD110_23_ uses with 2PCS BR1K2W6P8 braking resistors in series
 VFD150_23_ uses with 2PCS BR1K5W005 braking resistors in series

2. For 230V 25HP/30HP :

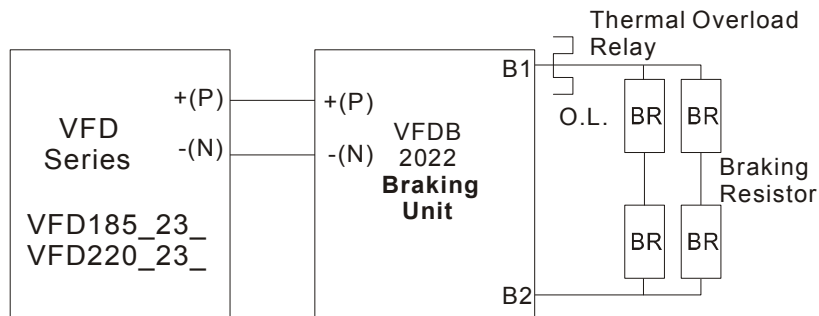

VFD185_23_ uses with two BR sets in parallel, which 2PCS BR1K2W008 braking resistors in series for each BR set.
 VFD220_23_ uses with two BR sets in parallel, which 2PCS BR1K2W6P8 braking resistors in series for each BR set.

3. For 230V 40HP/50HP:

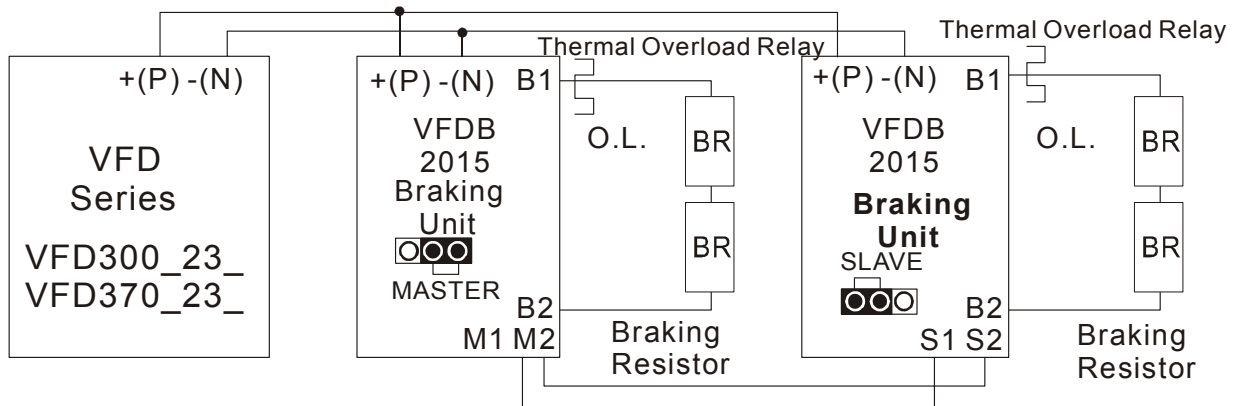

VFD300_23_ / VFD370_23_ use with two VFDB2015 braking units, and each braking unit uses with 2PCS BR1K5W005 braking resistors in series.

4. For 230V 60HP:

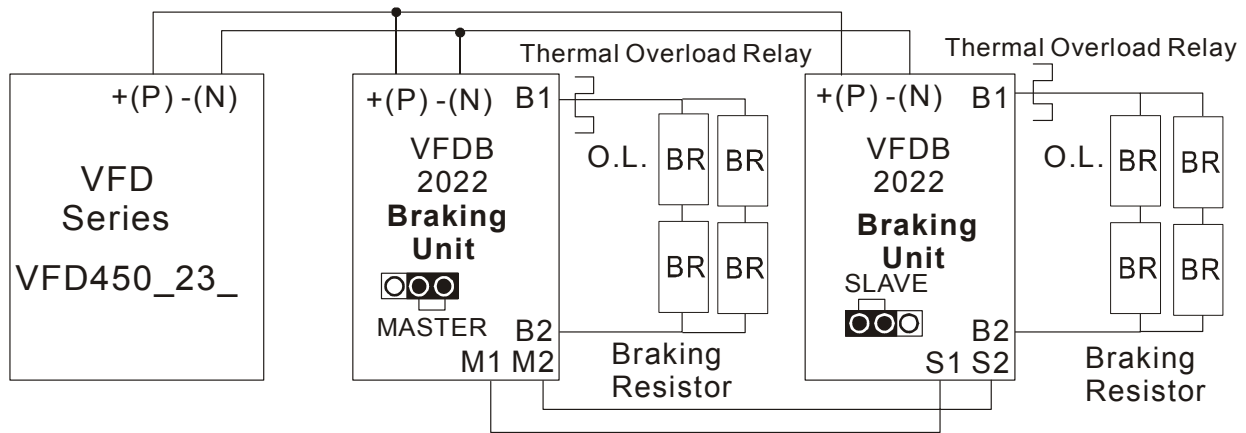

VFD450_23_ uses with two VFDB2022 braking units, and each braking unit uses with two BR sets in parallel, which 2PCS BR1K2W6P8 braking resistors in series.

5. For 460V 15HP/20HP:

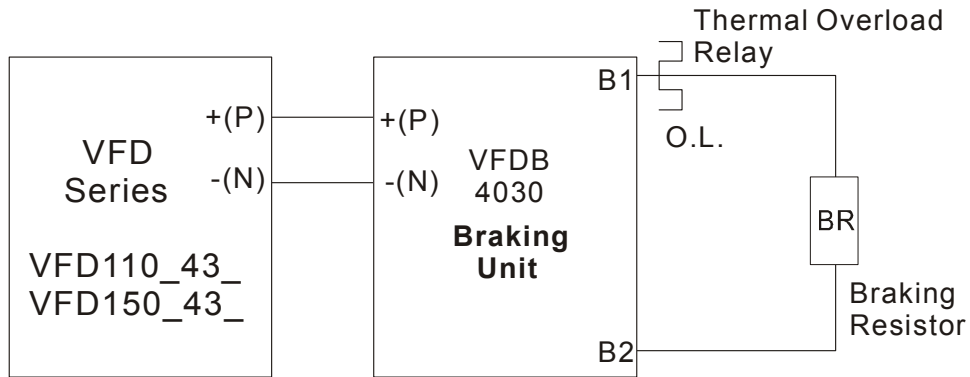

VFD110_43_ uses with 1PCS BR1K0W050 braking resistor
 VFD150_43_ uses with 1PCS BR1K5W040 braking resistor

6. For 460V 25HP/30HP/40HP:

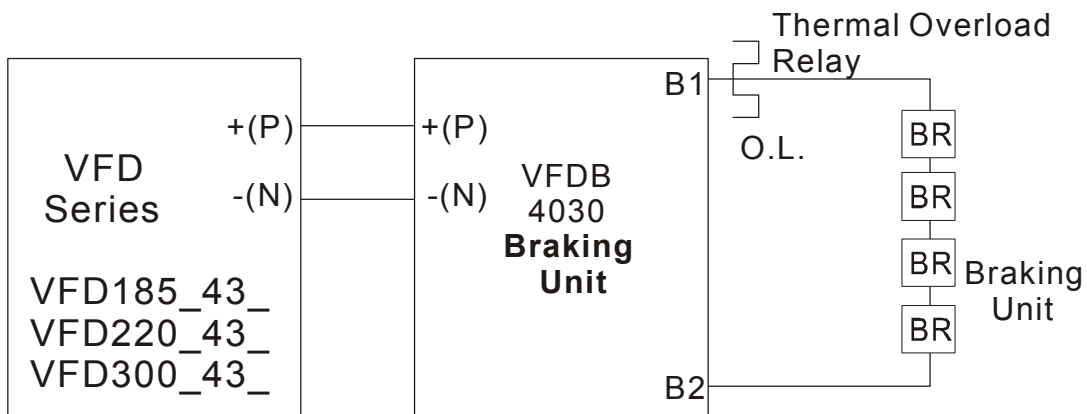

VFD185_43_ uses with 4PCS BR1K2W008 braking resistors in series
 VFD220_43_ uses with 4PCS BR1K2W6P8 braking resistors in series
 VFD300_43_ uses with 4PCS BR1K5W005 braking resistors in series

7. For 460V 50HP/60HP:

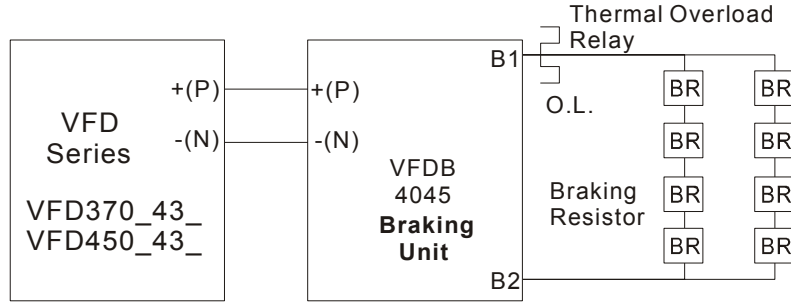

VFD370_43_ uses with two BR sets in parallel, which 4PCS BR1K2W008 braking resistors in series for each BR set.

VFD450_43_ uses with two BR sets in parallel, which 4PCS BR1K2W6P8 braking resistors in series for each BR set.

8. For 460V 75HP:

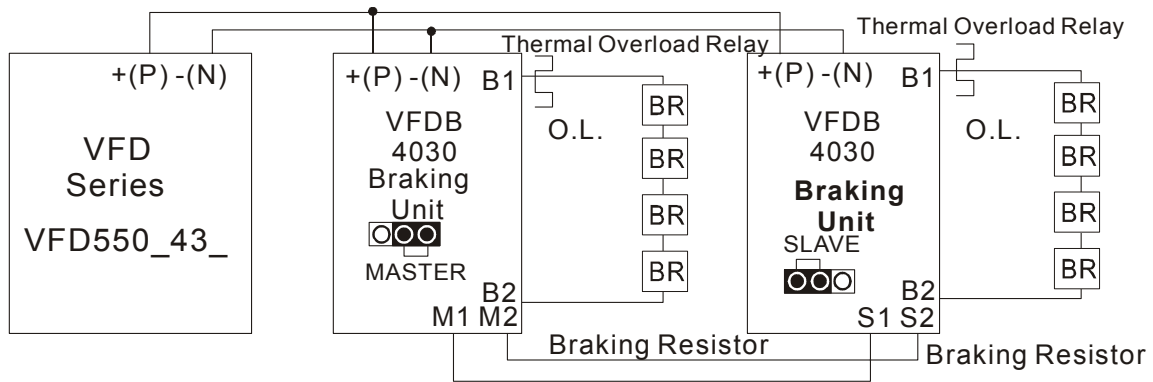

VFD550_43_ uses with two VFDB4030 braking units, and each braking unit uses with 4PCS BR1K5W005 braking resistors in series.

9. For 460V 100HP:

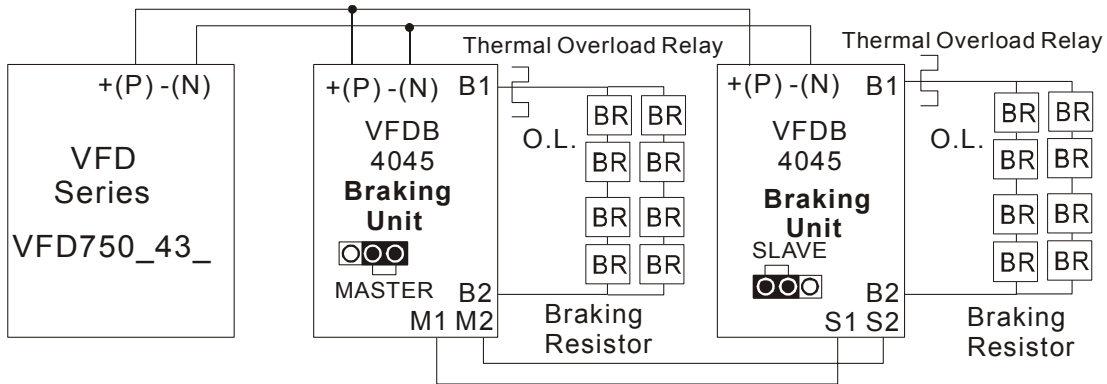

VFD750_43_ uses with two VFDB4045 braking units, and each braking unit uses with two BR sets in parallel, which 4PCS BR1K2W6P8 braking resistors in series.

5011620300
200407-28



UEI0

